

AN-109**Phase Noise Measurement of Z-Communications VCOs**

Phase noise of ZCOMM VCOs (free running) can be measured at different offsets, using the test set up and procedure below.

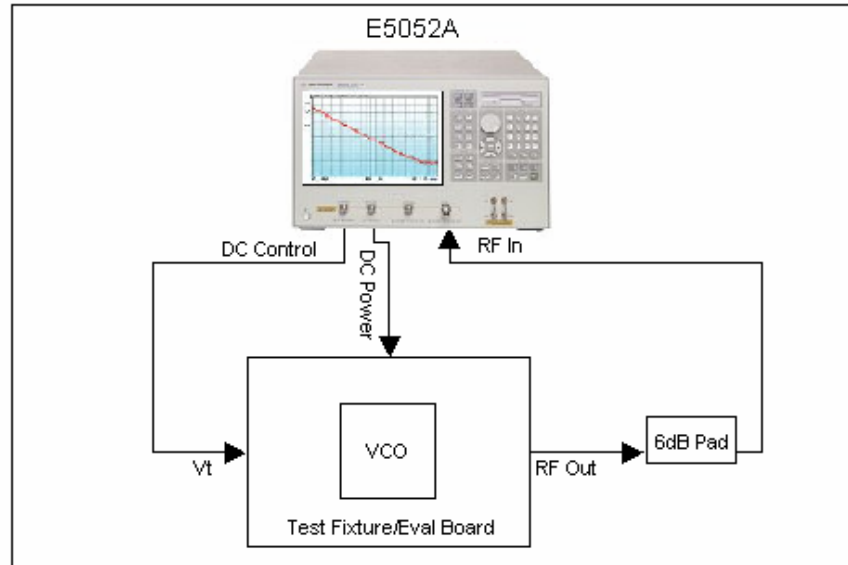

Figure AN-109:1- VCO Phase Noise Measurement Setup

Procedure using Agilent Technologies E5052A Signal Source Analyzer (10MHz-7GHz):

To ensure an accurate phase noise measurement, we use our eval boards or test fixtures. You can pick the appropriate one for the VCO you are using by referring to the link below:

http://www.zcomm.com/products/eval_boards.shtml

Test Setup

If you are using a ZCOMM test fixture:

Insert the VCO in the test fixture, making sure the orientation is correct and it is properly grounded. Then adjust the position of the test fixture latch so that it locks down on the VCO under test.

If you are using a ZCOMM eval board:

Solder the VCO with correct orientation to the eval board, ensuring proper GND contact.

We recommend using a minimum of 6dB pad at the RF-Out port of the test fixture, to ensure proper isolation and output load matching.

Using shielded (preferably double shielded) coaxial and RF cables with minimum possible length:

-Connect the Vt port (of test fixture/eval board) to DC Control (of Signal source Analyzer).

-Connect Vcc Port (of test fixture/eval board) to DC Power (of Signal Source Analyzer).

-Connect the RF Output port (of test fixture/eval board) with the 6-dB pad to RF In (of Signal Source Analyzer).

Test Procedure

Power on the Signal Source Analyzer.

Push the "Preset" button on E5052A. Then press the "Factory" soft key.

Press the "DC Power" button, then "DC Power Voltage" soft key, now enter the supply voltage value from the VCO's datasheet (for example, 5) then press the "x1" button.

Now click on the "DC Power Output" soft key, which should change to ON.

Press "DC Control" button on the E5052A, then "Auto Freq Control" soft key. Push "Target" soft key and type in the center frequency value from the VCO's datasheet (for example, if the frequency range stated on the datasheet is 136-174MHz, type in 155) and press "M/μ" button. This will set the frequency unit in MHz.

Press "Tolerance" soft key, type in 10 then press the "k/m" button to set the unit as KHz.

Press "Sensitivity" soft key, type in the sensitivity value from the VCO's datasheet (for example 14) and press "M/μ" to set the unit as MHz/V.

Press "AFC Status" soft key. Then press "ON" soft key. Press "DC Control" button, press "DC Control Output" soft key, which should change to ON.

Now you can set your markers at your desired offsets. Press "Marker" button on the Signal Source Analyzer.

-Press "Marker 1" soft key, type in 1 and press "k/m" button to set the unit as KHz.

-Press "Marker 2" soft key, enter 10 and press "k/m" button.

-Press "Marker 3" soft key, enter 100 then press "k/m".

-Press "Marker 4" soft key, enter 1 press "M/μ" and so on.

Please note that by pushing the "Start/Center" and "Stop/Span" buttons, you can choose your start and stop offset frequencies.

Now you should be able to see the phase noise plot (an example shown below in Figure AN-109:2), with some markers showing the phase noise values at different offsets.

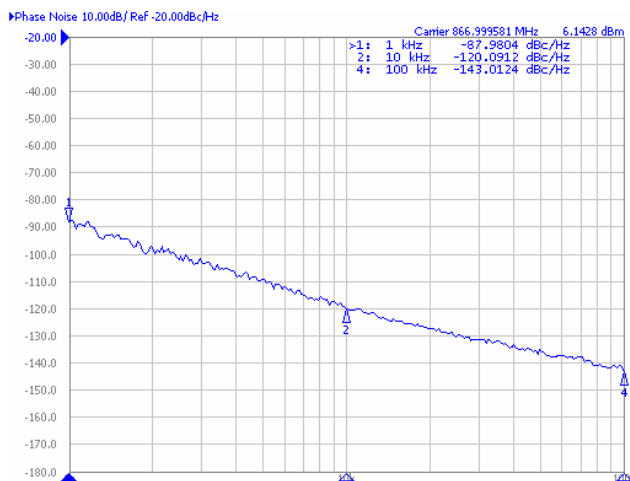

Figure AN-109:2- Phase Noise Plot

To have a smoother phase noise plot, you can push the "Avg/BW" button, then click on "Averaging" soft key which should turn to ON.

In cases one would like to measure the phase noise at higher offset (such as 10MHz), the correlation feature of E5052A can be used. This allows very low phase noise levels to be measured at higher offsets. You can press on "Correlation" soft key, then set the value to 1000 (or your desired value) and press "x1" button. Please refer to E5052A manual for details.

To save the plot, push the "System" button, then press on "Invert Image" soft key that should turn to ON. Then press on "Dump Screen Image" soft key to save the image to your desired directory.

If you need any further information, please contact applications@zcomm.com