

AN-205

Phase Noise Measurement of Z-Communications SFS Series

Phase noise of ZCOMM SFS series (fixed frequency synthesizers) can be measured by using the test set up and procedure below.

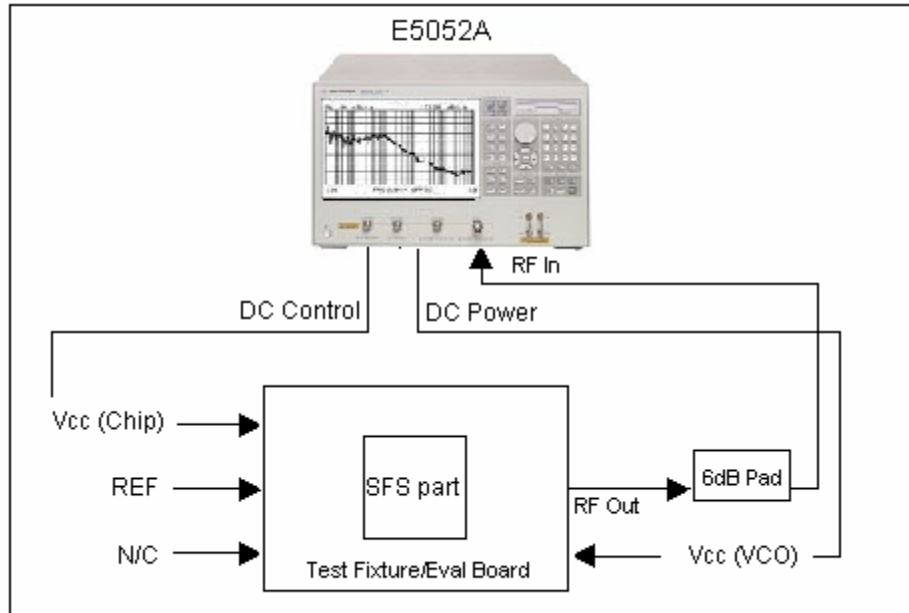

Figure AN-205:1- SFS Series Phase Noise Measurement Setup

Test Setup:

We use Agilent E5052A signal source analyzer to perform this test.

If you are using a ZCOMM SFS test fixture (PLL-V12N-Y):

Insert the SFS part in the test fixture, making sure the orientation is correct (the test fixture ports are labeled) and it is properly grounded. Adjust the position of the test fixture latch so that it locks down on the SFS part under test.

If you are using a ZCOMM eval board:

Solder the SFS part with correct orientation to the eval board, ensuring proper GND contact.

We recommend using a minimum of 6dB pad at the RF-Out port of the test fixture/eval board, to ensure proper isolation and output load matching.

Using shielded (preferably double shielded) coaxial and RF cables with minimum possible length:

- Connect the Vcc/Chip port (of test fixture/eval board) to DC Control (of Signal source Analyzer).
- Connect Vcc/VCO Port (of test fixture/eval board) to DC Power (of Signal Source Analyzer).
- Connect the RF Output port (of test fixture/eval board) to RF In (of Signal Source Analyzer).
- Connect the REF port (of test fixture/eval board) to your reference oscillator.
- Leave the N/C port (of test fixture/eval board) open.

Test Procedure:

Power on the Signal Source Analyzer.

Push the "Preset" button on Agilent E5052A. Then press the "Factory" soft key.

-Set the Vcc/VCO (DC Power) value from the SFS part datasheet.

-Set the Vcc/Chip value (DC Control) from the SFS part datasheet.

-Turn on both DC Power and DC Control.

-Set the frequency band under phase noise measurement (please refer to Agilent E5052A manual for more details).

-Turn the AVG on.

Now you can set your markers at your desired offsets. Press "**Marker**" button on the Signal Source Analyzer.

-Press "**Marker 1**" soft key, type in 1 and press "**k/m**" button to set the unit as KHz.

-Press "**Marker 2**" soft key, enter 10 and press "**k/m**" button.

-Press "**Marker 3**" soft key, enter 100 then press "**k/m**".

-Press "**Marker 4**" soft key, enter 1 press "**M/μ**" and so on.

Now you will be able to see the phase noise plot (an example shown below in Figure AN-205:2), with some markers showing the phase noise values at different offsets.

